



Rubber Design

vibration and noise control



Sandwich Mountings





DOCUMENTATION SHEET

Sandwich Mountings

SANDWICH MOUNTINGS

General

Available with or without interleaf, the VRD 34/35 type mountings are produced in a range of rubber hardness (M45, MN50, MN55 and MN60) and sizes, close to stiffness tolerances, for use as main and auxiliary engine mountings. This type of mounting can also be used in earthquake and shock areas. In that case, additional calculations are required. All mountings are individually tested and selected on stiffness.

Sandwich mountings, horizontally mounted for stationary applications

For land-based / stationary applications, sandwich mountings can be placed horizontally underneath the generator set, in order to provide a resiliently mounted system. Selection of the amount and rubber hardness of the sandwich mountings, as well as the position of the sandwich mountings, is done based on the weight of the installation, and the disturbing frequencies that have to be isolated.

Sandwich mountings are perfectly suited for these installations based on their high permanent workload capacity, and their excellent isolating capabilities, combined with a relatively low price. Besides, installation of these mountings is very easy, both on initial assembly as well as upon replacement of the sandwich mountings.

V-system

A combination of sandwich mountings arranged in a 'V' system allows considerable flexibility to the designer. The important natural frequencies can be positioned into the excitation free frequency bands and in addition seaway and torque movements are relatively low at the coupling position. A 'V' system applies to the installation of a main engine and particularly to a medium speed engine. With high speed engines the design is in most cases much simpler than that of the medium speed engine. The acoustic properties of the sandwich mountings are excellent. The result of the measured structure borne vibration and noise transmission are available. In both the vertical and horizontal direction, the transfer functions show in the low frequency range a decrease of 12 dB/octave which can be compared with an 'ideal massless spring characteristic'.

We will be pleased to undertake all suspension design calculation and advise on mounting type, quantity, position and rubber mix to ensure a 'faultless' flexible mounted installation. Before we can commence the design of a 'V' system, detailed information is required.

Mounting selection

The characteristics table is ideal for initial selection; however, it is advisable to seek expert advice before finalising an installation design. In practice most installations will be subject to both translational and rotational excitation and in consequence an analysis of all six degrees of freedom will be necessary. We will be pleased to advise on mounting numbers, rubber mix and mounting positions to ensure a 'faultless' flexible mounted installation.

Rubber Design gladly helps you with the engineering of your resilient mounted system. Vibration calculations are carried out using our specially developed computer programmes to meet new standards for both crews and passengers.

Shock / earthquake

The standard execution of the VRD 34/35 mountings can withstand shock-displacements up to 40% of the rubber height of the sandwich mount in lateral direction, and 20% in axial direction. This makes the mounting ideal for usage when equipment is placed in regions where earthquakes do occur. On application we can supply a special non-magnetic type manufactured in Inoxida.

Remarks

It is our intention to maintain the excellent standard of our products. Modifications and improvements may be made from time to time and it is therefore advisable to contact us before ordering.

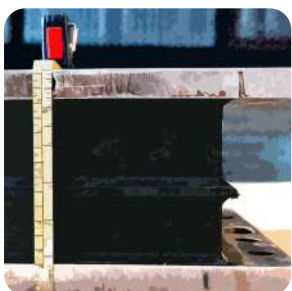



DOCUMENTATION SHEET

Sandwich Mountings

Type 34L1

34L1

| Hardness [°Sh. A] | Max Marine load [kN] | Max Static load [kN] | Max. Static vert. defl. [mm] |
|-------------------|----------------------|----------------------|------------------------------|
| 45° | 114 | 129 | 16 |
| 50° | 133 | 152 | 15,5 |
| 55° | 161 | 184 | 15 |
| 60° | 191 | 218 | 14,5 |

CHARACTERISTICS



TYPE APPROVALS

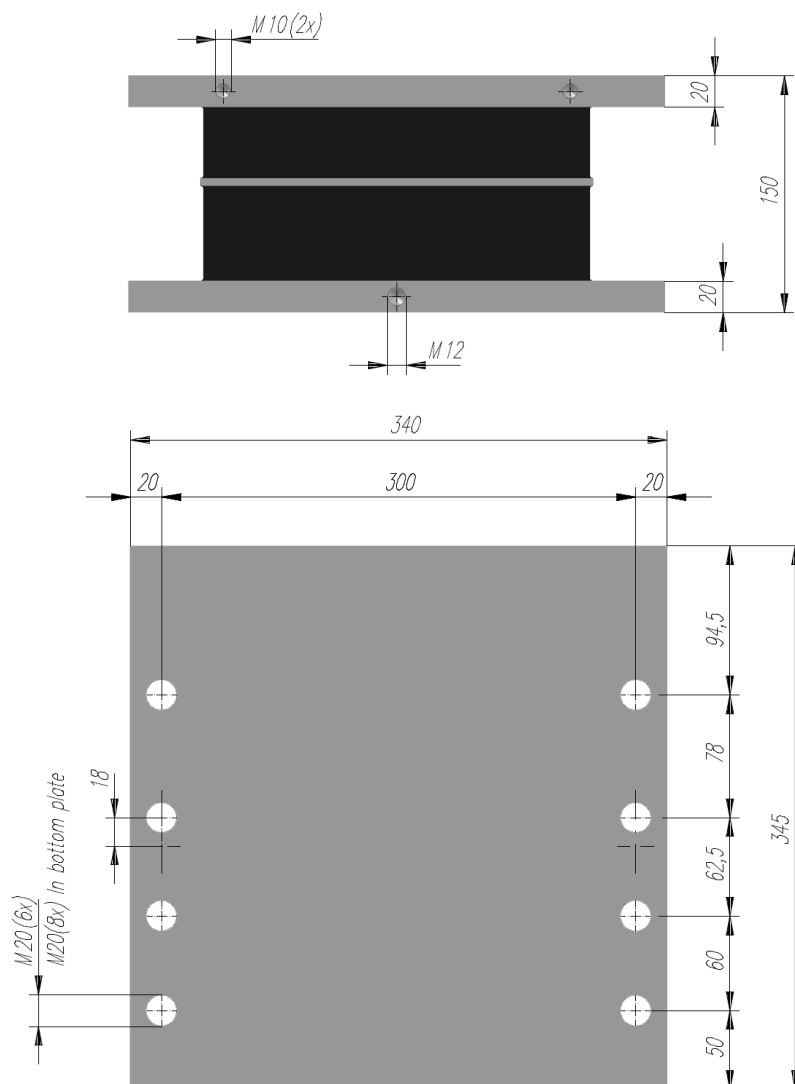
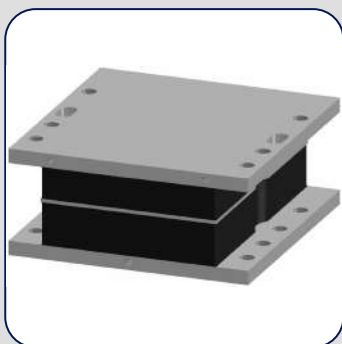

DIMENSIONS



DOCUMENTATION SHEET

Sandwich Mountings

Type 35L0

35L0

| Hardness [*Sh. A] | Max Marine load [kN] | Max Static load [kN] | Max. Static vert. defl. [mm] |
|-------------------|----------------------|----------------------|------------------------------|
| 45° | 57 | 65 | 16,0 |
| 50° | 69 | 78 | 15,0 |
| 55° | 84 | 95 | 14,5 |
| 60° | 95 | 108 | 13,5 |
| 65° | 105 | 118 | 13,0 |

CHARACTERISTICS



TYPE APPROVALS

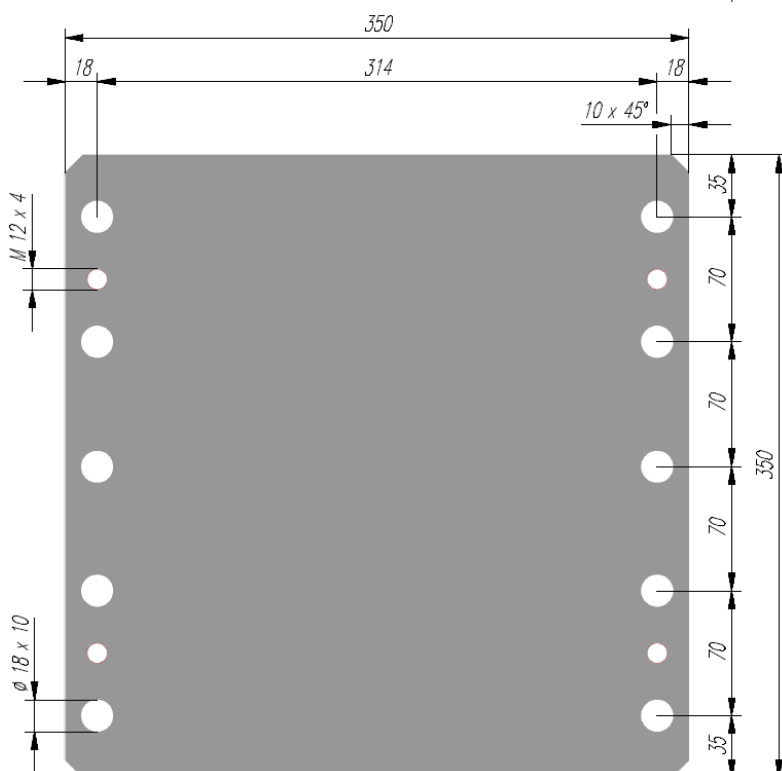

DIMENSIONS

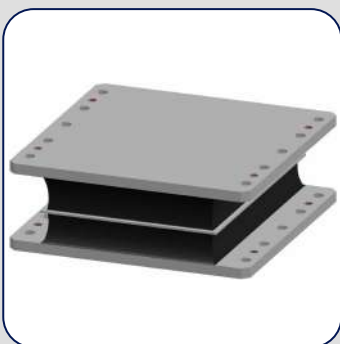



DOCUMENTATION SHEET

Sandwich Mountings
Type 35L1

35L1

| Hardness [*Sh. A] | Max Marine load [kN] | Max Static load [kN] | Max. Static vert. defl. [mm] |
|-------------------|----------------------|----------------------|------------------------------|
| 45° | 185 | 230 | 15,5 |
| 50° | 220 | 275 | 14,5 |
| 55° | 260 | 315 | 14,0 |
| 60° | 300 | 365 | 13,5 |
| 65° | 340 | 410 | 12,5 |

CHARACTERISTICS



TYPE APPROVALS

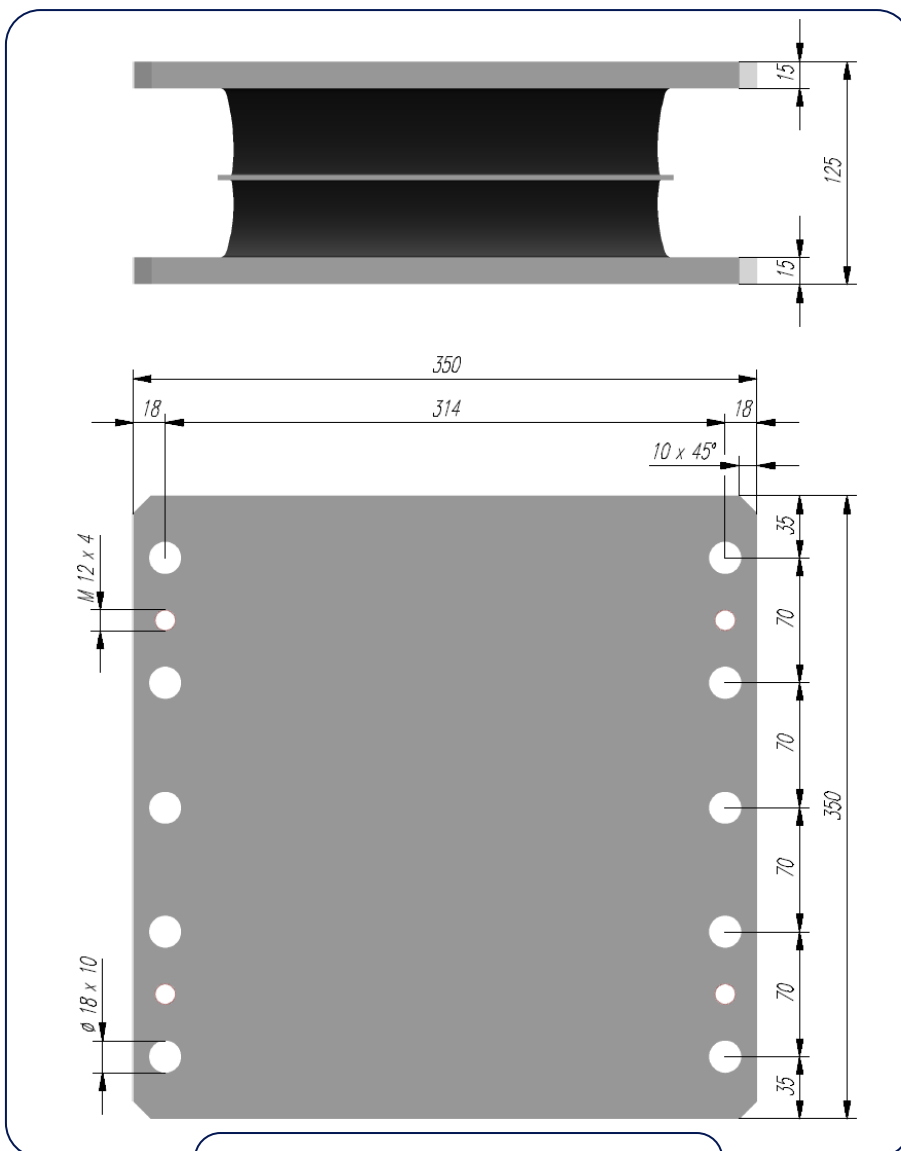

DIMENSIONS

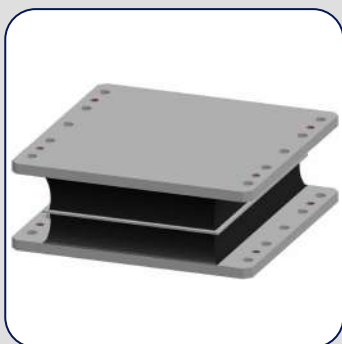



DOCUMENTATION SHEET

Sandwich Mountings

Type 35M0

35M0

| Hardness [*Sh. A] | Max Marine load [kN] | Max Static load [kN] | Max. Static vert. defl. [mm] |
|-------------------|----------------------|----------------------|------------------------------|
| 45° | 39 | 45 | 16,0 |
| 50° | 46 | 52 | 15,0 |
| 55° | 51 | 58 | 14,5 |
| 60° | 56 | 64 | 13,5 |
| 65° | 60 | 68 | 13,0 |

CHARACTERISTICS



TYPE APPROVALS

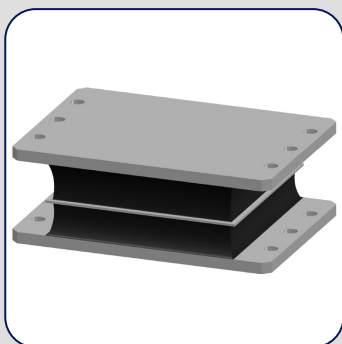
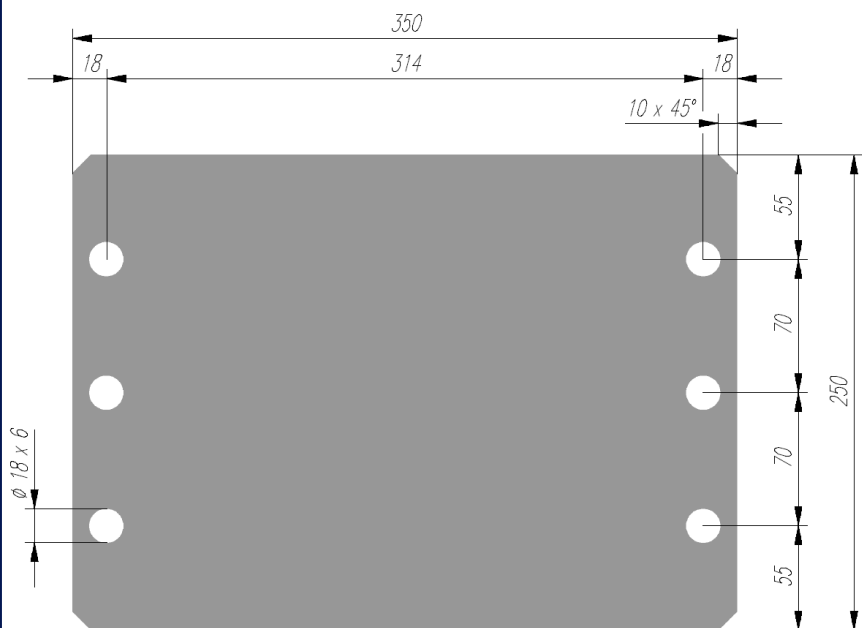

DIMENSIONS



DOCUMENTATION SHEET

Sandwich Mountings

Type 35M1

35M1

| Hardness [°Sh. A] | Max Marine load [kN] | Max Static load [kN] | Max. Static vert. defl. [mm] |
|-------------------|----------------------|----------------------|------------------------------|
| 45° | 105 | 125 | 15,5 |
| 50° | 119 | 142 | 14,5 |
| 55° | 130 | 155 | 14,0 |
| 60° | 140 | 167 | 13,5 |
| 65° | 150 | 178 | 12,5 |

CHARACTERISTICS



TYPE APPROVALS

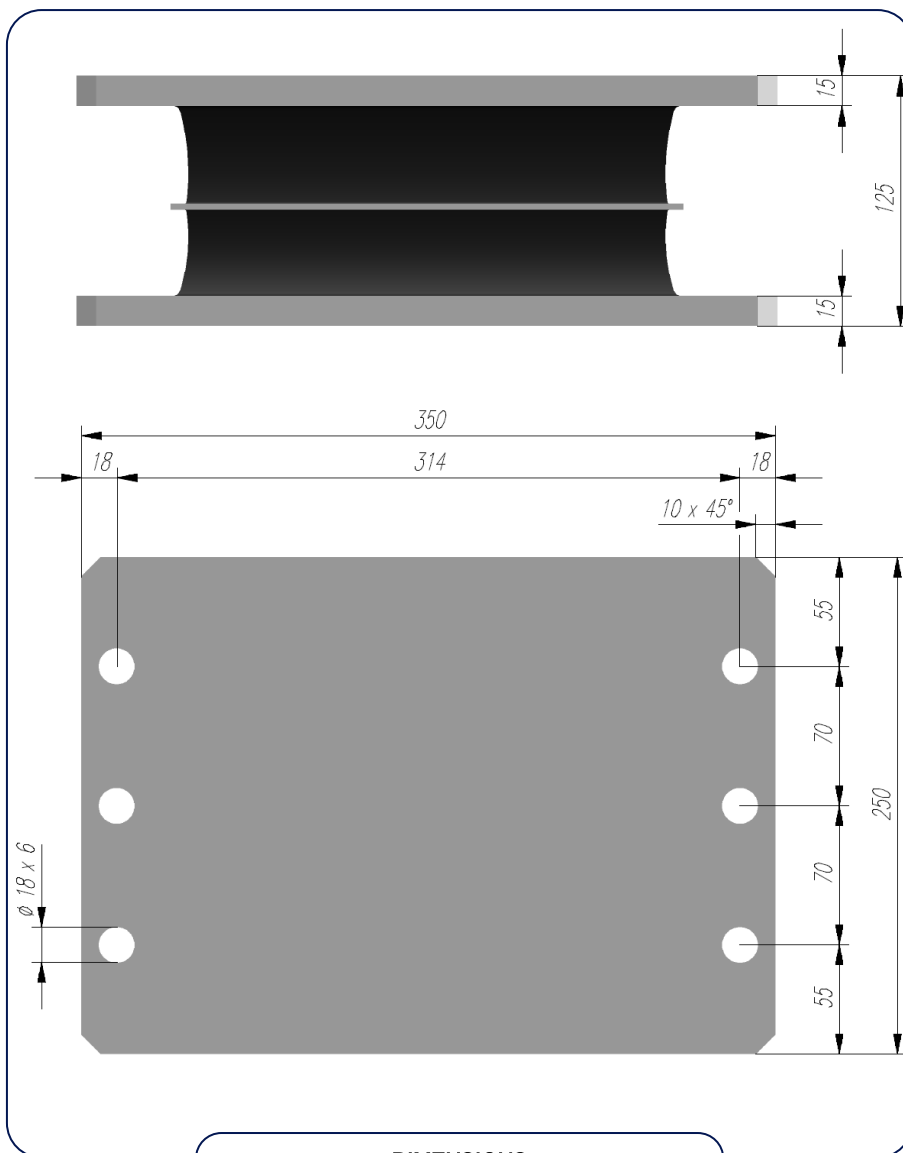

DIMENSIONS

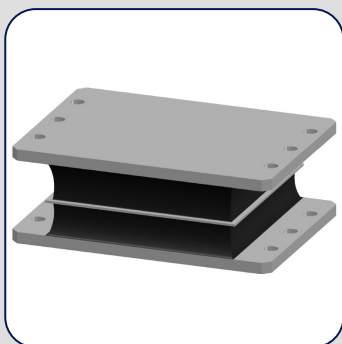



DOCUMENTATION SHEET

Sandwich Mountings

Type 35S0

35S0

| Hardness [*Sh. A] | Max Marine load [kN] | Max Static load [kN] | Max. Static vert. defl. [mm] |
|-------------------|----------------------|----------------------|------------------------------|
| 45° | 33 | 38 | 16,0 |
| 50° | 41 | 46 | 15,0 |
| 55° | 48 | 55 | 14,5 |
| 60° | 56 | 64 | 13,5 |

CHARACTERISTICS



TYPE APPROVALS

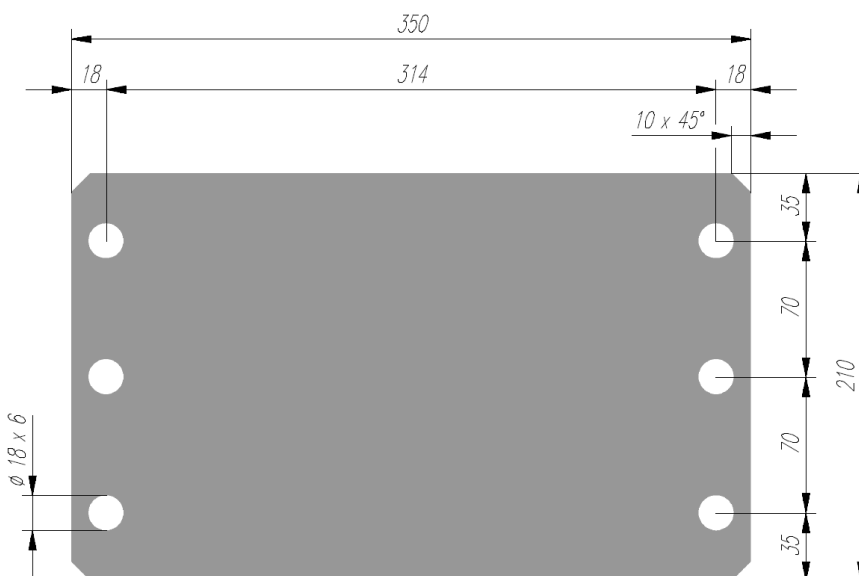

DIMENSIONS

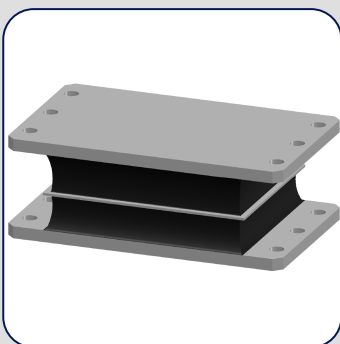



DOCUMENTATION SHEET

Sandwich Mountings

Type 35S1

35S1

| Hardness [°Sh. A] | Max Marine load [kN] | Max Static load [kN] | Max. Static vert. defl. [mm] |
|-------------------|----------------------|----------------------|------------------------------|
| 45° | 74 | 85 | 15,5 |
| 50° | 91 | 106 | 14,5 |
| 55° | 111 | 129 | 14,0 |
| 60° | 152 | 180 | 13,5 |

CHARACTERISTICS



TYPE APPROVALS



DIMENSIONS

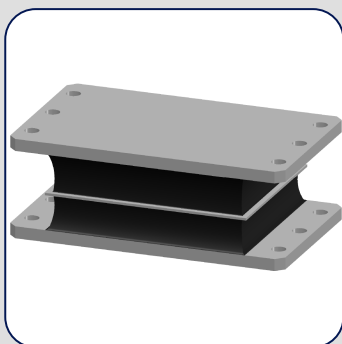



DOCUMENTATION SHEET

Sandwich Mountings Maintenance

MAINTENANCE

- The life expectancy of the rubber elements will be approx. 20 years in ideal circumstances. Unfortunately, ideal circumstances are not feasible, therefore the (working) life expectancy will be approx. 10 years. The life expectancy of the rubber elements is dependent on the environmental circumstances (weather influences, contaminants, etc).

- A visual inspection of the sandwich mountings should be carried out six months after installation and should be repeated every year. For better recognition of damages, a blunt pin can be used. The use of a screwdriver is not advisable, because of the damage it can cause to the sandwich mountings.

- The use of a natural rubber (NR) compound for the rubber elements means that they are not oil resistant. The occasional occurrence of oil leaks does not effect the working of the sandwich mountings, because the oil will only damage the surface of the rubber elements. In case of oil contamination the rubber elements will show some signs of swelling. Certainly elements showing signs of severe swelling or evidence of rubber to metal separation should be replaced. To prevent damage caused by oil contamination, the rubber elements can be treated with an oil resistant coating.

- When cleaning the engine room with a solvent cleansing agent, it is advisable to cover up the sandwich mountings. If the cleansing agent still contaminates the rubber elements, they should be cleaned as follows.

Storage, cleaning and maintenance of the rubber elements should be done in accordance with DIN 7716. The cleaning of the sandwich mountings should be done with a normal (household) cleansing agent. It is also advisable to use a glycerine-alcohol mixture (1:10). Do not use a solvent cleansing agent.

- If required, the customer can paint the sandwich mountings. Be aware that only the top- and baseplate of the sandwich mounting can be painted. Do not use paint on the rubber element as the rubber element might be contaminated and therefore be damaged.

- Each sandwich mounting has a serial number for identification, which will be used for replacement to deliver a complete new identical product or to replace the inserts of the mountings, in question with genuine inserts and/or parts.

| | | | | | | | | | |
|-----------|----------|-----------------|----------|-----------|----------|-----------|----------|-----------|-------------|
| RD | / | S1 | / | 60 | / | 05 | / | 08 | 3843 |
| Type | | Rubber hardness | | Date | | Serial nr | | | |

Type information can be found on the short side of the top baseplate. The above illustration gives the meaning of the used code.

- All deliveries are stored for over 20 years in a database including all relevant data and characteristics. V-positioned sandwich mountings In cases where it is necessary to replace the rubber insert, we advise to return the complete sandwich mounting to Rubber Design BV. The central buffer clearance should be examined and reset if necessary after the first week, after three months, and thereafter to fit in with normal maintenance programmes.





DOCUMENTATION SHEET

Sandwich Mountings

Installation instruction

INSTALLATION INSTRUCTION

Mounting and adjustment instructions for horizontally placed sandwich mountings

The sandwich mountings must be mounted on the prepared brackets on the base frame.

- 1) Fit the sandwich mountings to the bracket on the base frame by means of four M16 bolts.
- 2) Align the generating set above the foundation frames. The mounting holes in sandwich mounting must be aligned with the holes in the foundation frames.
- 3) Place a steel chock on the foundation frame underneath each sandwich mounting. Thickness of steel chock: 20 mm.
- 4) Lower the generating set until it rests completely on the sandwich mountings
- 5) After 48 hours, level and load distribution should be checked by measuring the height of the sandwich mounting. The difference between the sandwich mountings should be as small as possible and should not exceed ± 2 mm.

Example:

$$Average = \frac{H_1 + H_2 + H_3 + \dots + H_n}{N} \text{ mm}$$

N = number of sandwich mountings

The difference between the two sides of a sandwich mounting should not be more than 1 mm.

- 6) The mounting (s) with the largest deviation (from the average) should be adjusted first. By machining the steel chock or adding thin steel shims between the sandwich mounting and the steel chock.

Mounting of sandwich elements on the foundation frame.

- 7) Fix all the sandwich mountings and the steel chocks to the foundation frame with four bolts per sandwich.

Mounting and adjustment instructions for V-positioned sandwich mountings.

This instructions can be sent upon request.

